



## Operator Training Simulation Software for Power Generation & Oil and Gas

# Operator Training Simulation Software for Power Generation & Oil and Gas



## TSI Operator Training Simulators for Power Generation Plants

The range of TSI Power Plant Simulators provide PC-based hi-fidelity, full-scope dynamic Operator Training Simulators that meet the operator training requirements of any coal/oil or gas fired power plant.

Each model is designed to operate over a variety of actual power plant operating conditions.

These include:

- Cold start (no fuel, no utilities, pumps off, controllers in manual, etc.)
- Design Start (normal operating conditions)
- Restart from Trip Conditions
- Normal and Emergency Shut-downs

The simulators can be connected to the TSI Hard-desk System and the instructor and the trainees can control the power system from the soft-desk.

### Instructor Station

The Instructor Station enables the instructor to control and direct the training sessions. They can assign multiple independent training sessions to one or more of the networked operator stations.

The graphics interface and easy to use menus allow the Instructor to work efficiently, even with a large group of trainees.

Facilities include:

- Start up mode selection - Normal and Design Start
- Speed - Normal up to 10x normal operating speed
- History - Back-track or Snapshot
- Malfunction - Failure or Disturbance
- Tag summary
- Summary report
- PV logging
- Trend logging
- Realtime trend logging
- Monitor exercise
- Performance report
- Message to operator
- Full plant report

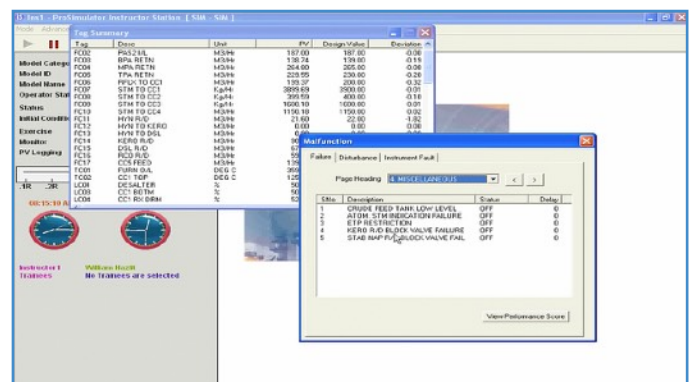

# Operator Training Simulation Software for Power Generation & Oil and Gas



## Operator Station

The Operator Station provides all the functionality of the associated DCS and the connected plant.

Under the direction of the Instructor Station, a series of operating scenarios are presented to the trainee and they have to respond accordingly.

These include both faulted and non-faulted conditions.

Our system provides emulation for several standard DCS (Distributed Control System) interfaces including:

- Yokogawa Centum CS3000/VP
- Honeywell TDC3000/Experion
- Fox I/A
- Siemens PCS7
- Delta V
- ABB Harmony

All the functions and features that are essential for training are included. Using this system operators learn dynamic process interactions as well as the specific control and monitoring procedures for the plant.

Using a PC keyboard or simulated keyboard (on-screen keyboard) or an optional emulated DCS keyboard, the trainee can operate the simulated plant across its full dynamic range.

The simulated windows for the emulated DCS that are provided to operate the simulator are:

- Overview Window
- Control Group Window
- Tuning Window
- Graphic Window
- Trend Window
- Process Alarm Summary Window

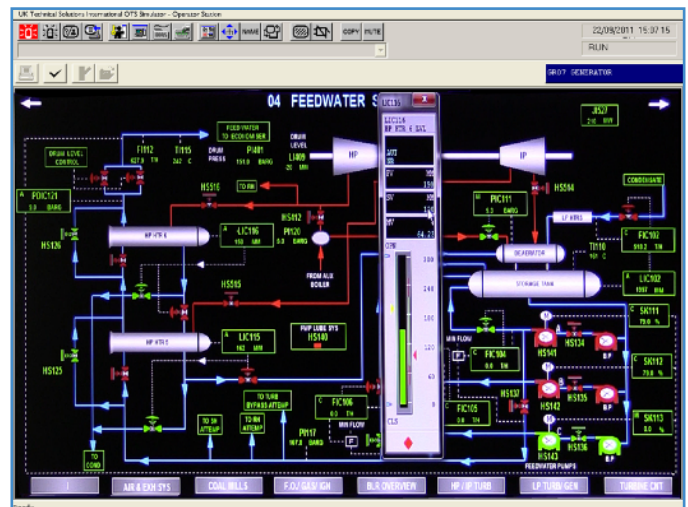

# Operator Training Simulation Software for Power Generation & Oil and Gas

## TSI-PTSS 50200 Power Systems Simulation Software – Thermal Power Plant 210 MW

### Capacity: 210 MW

#### Fuels

- Coal
- Heavy Oil (warm-up)
- Light Oil (ignition)

#### Steam Generator

- Drum type
- Natural Circulation

#### Furnace Air and Gas Systems

- 2 Forced Draft Fans
- 2 Induced Draft Fans
- 4 Primary Air fans (1 for each Pulveriser)
- 1 Igniter Fan & 1 Scanner Fan
- Windbox
- 1 Regenerative Air Heater
- Soot blowers
- Electro-static precipitator

#### Fuel and Burner Systems

- 4 Coal Feeders
- 4 Pulverisers
- 2 Ignition Oil pumps
- 2 Fuel Oil Pumps
- Coal and Oil Burners at 4 Levels

#### Boiler Water and Steam Systems

- Economiser
- Steam Drum
- Downcomer
- Waterwalls
- Primary Superheater
- Secondary Superheater
- Reheater
- Attemperators for Superheater
- Auxiliary Steam Header

#### Turbine and Generator Systems

- HP/IP/LP Turbines
- Main Stop Valve with Bypass
- 4 Turbine Control Valves
- Turbine Turning Gear
- 2 Turbine Lube Oil Pumps
- Turbine Lube Oil Cooling Water Pump
- Bearing vibration monitors
- Generator with Exciter and AVR
- Synchroscope

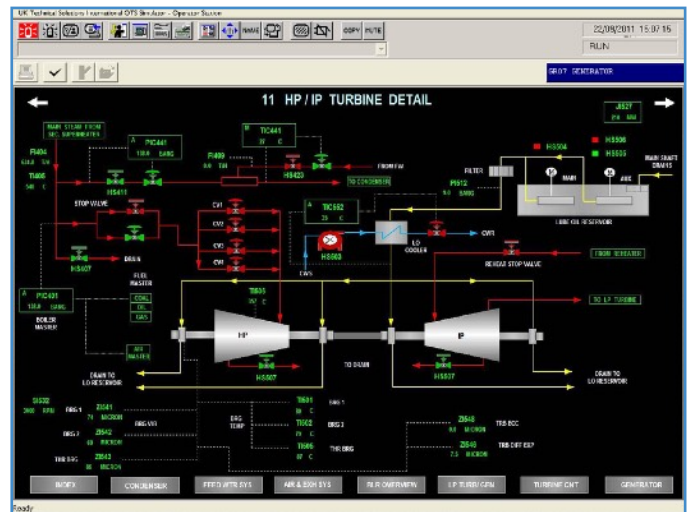

- Hydrogen Cooler
- Hydrogen Seal Oil Pump
- Stator Cooling water Pump Condensate and

#### Feedwater System Equipment

- Condenser
- 2 Air Ejectors
- 2 Circulating Water Pumps
- 2 Condensate Extraction Pumps
- Condensate Storage Tank
- 1 Makeup Pump
- Air Ejector Steam Condenser
- Gland Seal Steam Condenser with Exhaust Fan
- Condensate Scrubber
- 3 Low Pressure Heaters
- De-aerator with Storage Tank
- 2 High Pressure Heaters
- 3 Boiler Feed Pumps (motor driven)

#### Instrumentation

- 43 Controllers
- 17 Auto-Manual Control Stations
- 17 Manual Stations
- 127 Indicators
- 131 Switches
- 80 Explicit Alarms
- Trips and Alarm Logic / Interlocks.

#### Instructor Functions

- Pump trips/Fan trips
- Turbine trip/Generator trip
- Fuel trip
- Valve malfunctions
- Instrument malfunctions
- Air temperature
- Cooling water temperature
- Low grade fuel

# Operator Training Simulation Software for Power Generation & Oil and Gas

## TSI-PTSS 50210 Power Systems Simulation Software – Gas Turbine Power Plant 42 MW

**Capacity: 42 MW**

### Fuels

- Natural Gas
- Fuel Oil

### Equipment

- **Air System:**
- Air intake louvre
- Air filter,
- Compressor for pulsation cleaning of air filter
- Anti-icing air heater
- Multi-Stage axial compressor with variable inlet guide vanes

### Fuel Gas System:

- ESD Valve, Knock-out drum
- Steam heater
- 2 Coalescing filters
- Vent valves and Control valves for ignition and main fuel

### Fuel Oil System:

- Fuel Oil Tank
- 2 Fuel Oil Pumps
- Steam Heater

### Combustion Chamber:

- Main Burners
- Ignition Burners
- Flame Monitors
- Vibration Monitors

### Turbine and Generator:

- Multi-Stage Gas Turbine
- Bearing vibration monitors, Rotor displacement and phase angle monitors
- Turbine blades wash system
- Generator with Exciter and Automatic Voltage Regulator
- Synchroscope
- Static start-up device
- Main Transformer
- Voltage Regulator Transformer
- Air circulation fans and Water Coolers for air

### Auxiliary Systems:

- Lube oil reservoir
- Electrical Heater
- Oil reservoir exhaust fan
- 2 Main lube oil pumps
- Emergency lube oil pump

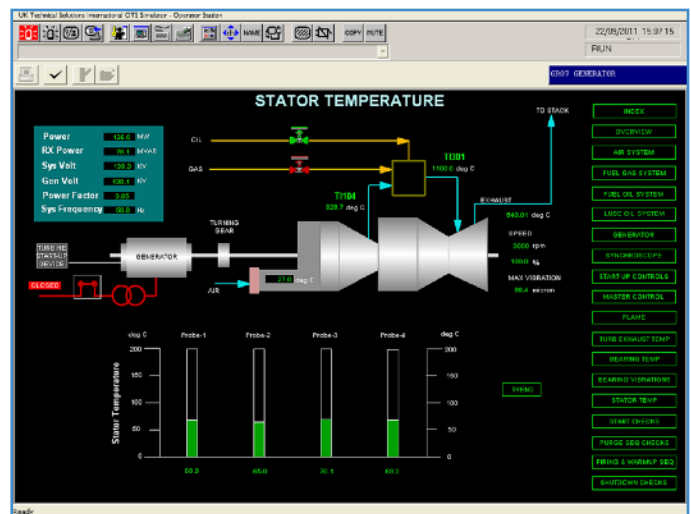

- Lube oil cooler
- 2 Lube oil filters
- 2 Power oil pumps
- 1 Power oil filter
- 1 Jacking oil pump
- 1 Rotor barring pump
- 2 Oil pressure accumulators System
- Acceleration Control
- Manual Suppression of the Fuel Reference
- Speed Control
- Temperature Control
- Start-up Control
- Shut-down Control
- Operating Limit

### Graphics

- Index
- Compressor, Gas Turbine-Generator Overview
- Air Intake System & Compressor
- Fuel Gas and Ignition Systems
- Fuel Oil System
- Gas Turbine and Generator
- Gas Turbine Lube Oil and Power Oil System
- Gas Turbine and Generator in various start-up & control modes

### Instructor Functions

- Air temperature/Humidity
- Grid Frequency
- Pump trips
- Compressor trip
- Turbine trip
- Generator trip
- Fuel trip
- Tube Leaks
- Valve malfunctions
- Instrument malfunctions
- False alarms

# Operator Training Simulation Software for Power Generation & Oil and Gas

## TSI-PTSS 50220 Power Systems Simulation Software – Combined Cycle Gas Turbine Power Plant 450 MW

**Capacity: 450 MW**

**Fuels**

- Natural Gas
- Fuel Oil

**Equipment**

- Circulating water pump
- Gland steam condenser
- Feed water
- Condenser circulating water
- Make up water
- Air Compressor
- Evaporator
- Heat Recovery Steam Generator (HRSG)
- Steam Combustion Heat exchanger
- Burner
- Filter Fuel (Gas, oil)
- De-aerator
- Turbine
- Generator
- DC excitation Transformer

The simulated plant has the following features:

- Two Gas Turbines
- Two HRSG's with Supplementary firing
- One steam turbine
- Condenser
- Typical condensate and feed water systems
- Typical generation and power transmitting systems
- Typical HMI control system.
- Typical utility, auxiliary and ancillary systems for all the above-mentioned systems.

**Control System:**

- Load control
- Combustion control
- Steam air heater temperature control
- Feed water flow and drum level control
- Differential pressure control of feed water and economiser
- Steam temperature control
- HPT bypass control
- LPT bypass control
- Condenser hotwell level control
- Condenser pumps recirculation control
- Condenser flow and de-aerator level

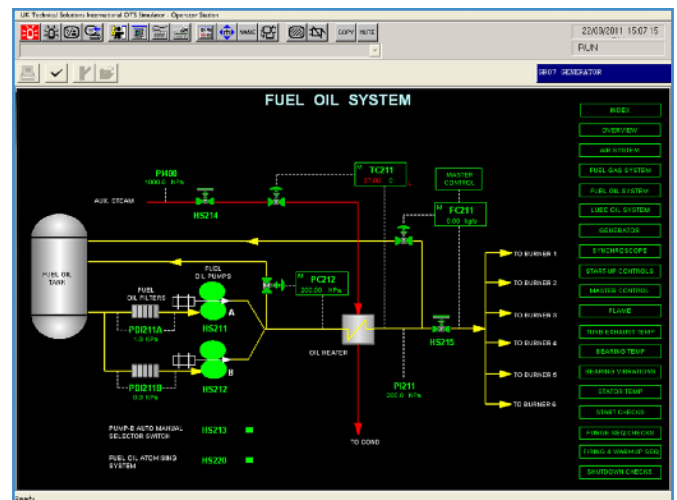

- Feed water pumps and recirculation control
- Feed water heater level control
- Turbine gland steam pressure control
- Compressor control
- Flue gas temperature control
- Filter control
- Turbine exhaust hood temperature control
- Turbine lube oil temperature control
- Generator temperature control
- Evaporation rate control

### Alternative Energy OTS

In addition to traditional carbon fired power plants, we are also able to offer a range of alternative energy power plant simulators on



# Operator Training Simulation Software for Power Generation & Oil and Gas

## TSI-PTSS 50230 Power Systems Simulation Software – Thermal Power Plant 600 MW

**Capacity: 600 MW**

### Fuels

- Coal
- Heavy Oil (warm-up)
- Light Oil (ignition)

### Steam Generator

- Drum type
- Natural Circulation

### Furnace Air and Gas Systems

- Forced Draft Fans
- Induced Draft Fans
- Primary Air fans (1 for each Pulveriser)
- Igniter Fan & I Scanner Fan
- Windbox
- Regenerative Air Heater
- Soot blowers
- Electro-static precipitator

### Fuel and Burner Systems

- 6 Coal Feeders
- 6 Pulverisers
- Ignition Oil pumps
- Fuel Oil Pumps
- Coal and Oil Burners at 4 Levels

### Boiler Water and Steam Systems

- Economiser
- Steam Drum
- Downcomer
- Waterwalls
- Primary Superheater
- Secondary Superheater
- Reheater
- Attemperators for Superheater
- Auxiliary Steam Header

### Turbine and Generator Systems

- HP/IP/LP Turbines
- Main Stop Valve with Bypass
- Turbine Control Valves
- Turbine Turning Gear
- Turbine Lube Oil Pumps
- Turbine Lube Oil Cooler
- Turbine Lube Oil Cooling Water Pump
- Bearing vibration monitors
- Rotor eccentricity monitor
- Generator with Exciter and AVR
- Synchroscope

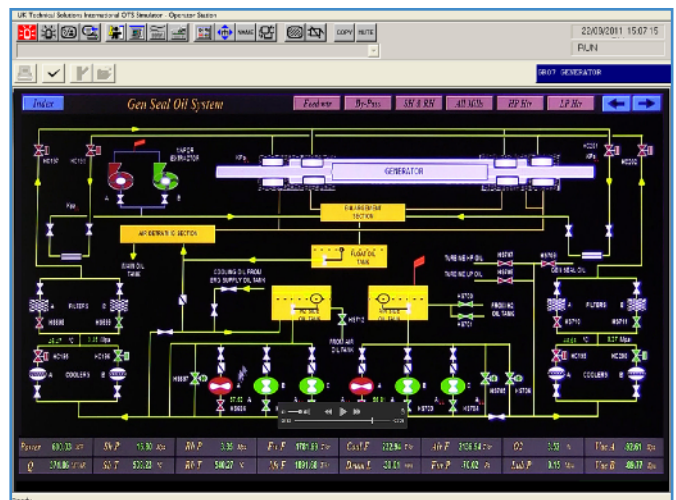

- Hydrogen Cooler
- Hydrogen Seal Oil Pump
- Stator Cooling water Pump

### Condensate and Feedwater System Equipment

- Condenser
- Air Ejectors
- Circulating Water Pumps
- Condensate Extraction Pumps
- Condensate Storage Tank
- Makeup Pump
- Air Ejector Steam Condenser
- Gland Seal Steam Condenser with Exhaust Fan
- Condensate Scrubber
- Low Pressure Heaters
- De-aerator with Storage Tank
- High Pressure Heaters
- Boiler Feed Pumps (motor driven)

### Instrumentation

- Controllers
- Auto-Manual Control Stations
- Manual Stations
- Indicators
- Switches
- Explicit Alarms
- Trips and Alarm Logic / Interlocks.

### Instructor Functions

- Pump trips
- Fan trips
- Turbine trip
- Generator trip
- Fuel trip
- Valve malfunctions
- Instrument malfunctions
- Air temperature
- Cooling water temperature

# Operator Training Simulation Software for Power Generation & Oil and Gas

## TSI-PTSS 50350 Power Systems Simulation Software – Gas Turbine Power Plant 350 MW Capacity: 450 MW

### Fuels

- Natural Gas
- Fuel Oil **Equipment:**

### Air System:

- Air intake louver, Air filter,
- Compressor for pulsation cleaning of air filter,
- Anti-icing air heater,
- Multi-Stage axial compressor with variable inlet guide vanes

### Fuel Gas System:

- ESD Valve
- Knock-out drum
- Steam heater
- 2 Coalescing filters
- Vent valves and Control valves for ignition and main fuel

### Fuel Oil System:

- Fuel Oil Tank
- 2 Fuel Oil Pumps
- Steam Heater

### Combustion Chamber:

- Main Burners
- Ignition Burners
- Flame Monitors
- Vibration Monitors

### Turbine and Generator:

- Multi-Stage Gas Turbine
- Bearing vibration monitors
- Rotor displacement and phase angle monitors, blades wash system,
- Generator w/ Exciter and Automatic Voltage Regulator
- Syncope
- Static start-up device
- Main Transformer
- Voltage Regulator Transformer,
- Air circulation fans and Water Coolers for air

### Auxiliary Systems:

- Lube oil reservoir
- Electrical Heater
- Oil reservoir exhaust fan
- 1 Main lube oil pump
- 1 Auxiliary lube oil pump

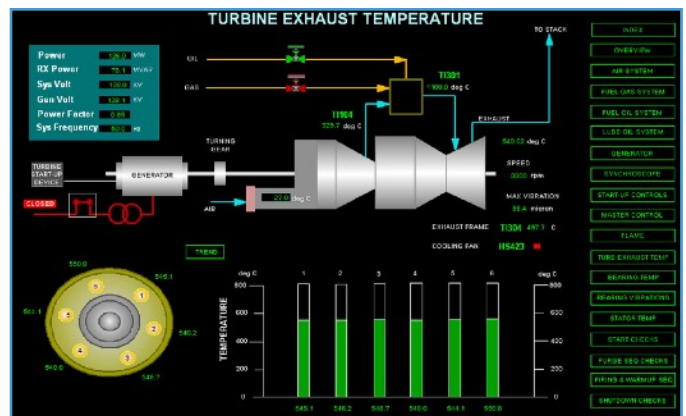

- Lube oil cooler
- 2 Lube oil filters
- 2 Power oil pumps
- 1 Power oil filter
- 1 Turbine gear oil pump
- 2 Oil pressure accumulators

### Control system:

The following main functions are included:

- Acceleration Control
- Speed Control
- Temperature Control
- Start-up Control
- Shut-down Control
- Operating Limit

### Instructor functions:

- Air temperature
- Air Humidity
- Grid Frequency
- Pump trips
- Compressor trip
- Turbine trip
- Generator trip
- Fuel trip
- Tube Leaks
- Valve malfunctions
- Instrument malfunctions
- False alarms.



# Operator Training Simulation Software for Power Generation & Oil and Gas

## TSI-PTSS 50800 Electrical Operations Simulator Suite

This suite of simulators has been put together to offer a basic introduction to the typical electrical operations found in a power plant. We only focus on the main electrical elements:

- Generator
- Generator Cooling Water System
- 6.6kV System
- 220kV Switch Yard

Each individual simulator is fully functional and makes an ideal front of class teaching resource for the Instructor.

### 220 kV Generator

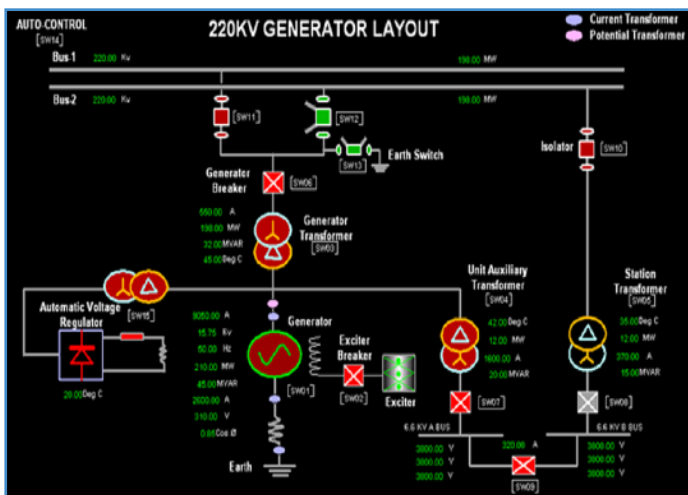

A machine, that converts mechanical energy into electrical energy, using the electromagnetic induction principle, is known as an AC generator. When the rated speed of 3,000rpm is achieved by the prime mover, which is coupled with the generator rotor shaft, DC voltage is injected into the rotating field device via slip rings and brushes. This creates a flux field and a corresponding AC voltage output. Then generator can then be synchronised with the grid frequency and voltage.

The generator can produce a terminal voltage of 15.75kV which can be attained using an automatic voltage regulator(AVR). This voltage is stepped-up using a generator transformer (GT) into a 220kV voltage which is then fed into the main bus using circuit breaker (CB) and isolator arrangements.

Then using a unit auxiliary transformer (UAT) voltage is stepped down 15.75/6.6kV which serves as the power source for all the power plant auxiliary equipment when the unit is in running condition.

A Station transformer (ST) steps down the voltage from 220/6.6kV which is given to the 6.6kV bus, it acts as a power source when the unit is in stand-by condition. A bus coupler is provided between the two 6.6kV bus lines in order to share the load between the two buses.

### Interlocks:

- When the generator trips then the generator circuit breaker has to open.
- When the generator trips then ST CB has to close and UAT TCB has to open in AUTO.
- When the generator is live, if UAT CB opens then ST CB has to close immediately.
- When the transformer excitation CB opens the generator has to trip.
- When DC Excitation fails then the generator has to trip.

### Generator Cooling Water System

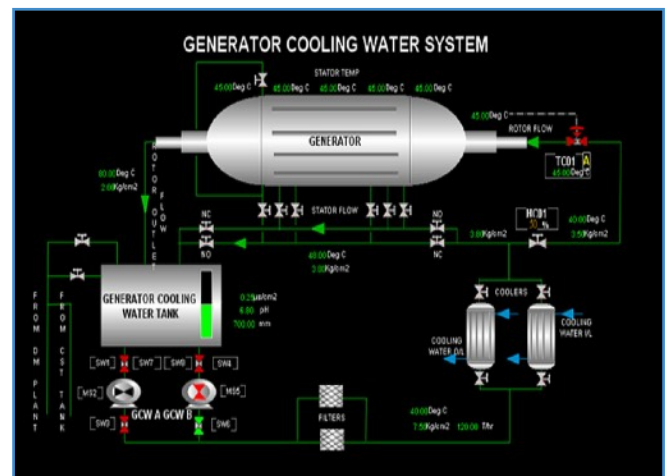

Cooling of the Generator will improve the system efficiency and life of generator. Moreover, this will maintain the temperature of the windings and components of the generator resulting a reduction of various losses.

De-Mineralised (DM) water is used for cooling but the conductivity must be maintained below  $5\mu\text{s}/\text{cm}$ . It is first stored in a tank from which water is pumped to the stator core using a generator cooling water pump.

# Operator Training Simulation Software for Power Generation & Oil and Gas

The pressure and flow of the cooling water must be maintained at 3 Kg/cm<sup>2</sup> and 25 T/hr. The temperature must be monitored at various points and must be maintained below 50 deg C.

The return line is taken back to the cooling water storage tank and cooled there it is then circulated back into the process.

## Control Schemes

- Pressure and flow controller at GCW P/P
- Temperature controller

## Interlocks

- When one GCW P/P trips then the other has to start in AUTO.
- When the pressure drops below 2Kg/Cm<sup>2</sup> the 2<sup>nd</sup> ICW P/P has to start in AUTO
- When both side inlet valves close then the running GCW will cause a trip.

## 6.6 kV System

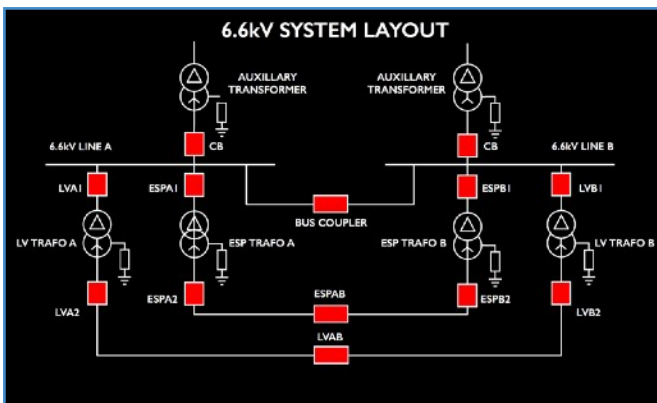

The 6.6 kV system consists of two buses A & B. Bus A is supplied by the Unit Auxiliary Transformer (UAT), and bus B is supplied by the Station Transformer (ST). Both these act as the power source for these two buses. It is provided with a bus coupler to share the load between the two buses.

A Unit Auxiliary Transformer (UAT) steps down 15.75/6.6kV which is given to the 6.6kV bus A, which serves as the power source for all the auxiliary equipment when the unit is in running condition.

A Station Transformer (ST) steps down the voltage from 220/6.6kV which is given to the 6.6kV bus B, it acts as a power source when the unit is in stand-by condition.

Bus A & B supply power for the ESP transformer and the low voltage transformers (A&B) respectively. Both these transformers are provided with an incoming and an outgoing circuit breaker and a bus coupler.

The low voltage transformer acts as a step down transformer which converts 6.6kV to 415V which acts as a power supply for all the low voltage equipment. The ESP transformer serves as a source for all the ESP fields.

## Interlocks:

- When Unit Auxiliary Circuit Breaker opens then ST circuit breaker has to close in AUTO.
- When incomer circuit breaker of ESP or LV TRAF0 opens then it's corresponding outgoing circuit breaker has to open in AUTO.
- When one side of ESP or LV TRAF0 fails then it's bus coupler has to close in AUTO.

## 415 V System

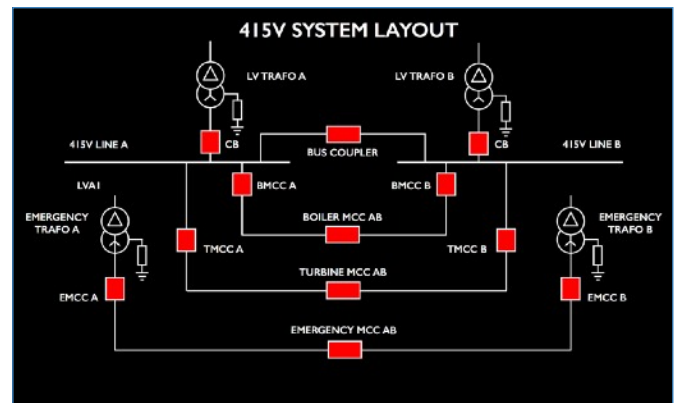

The 415 V system consists of two buses A & B. Bus A is supplied by Low Voltage Transformer A and bus B is supplied by Low Voltage Transformer B. Both these act as the power source for the Boiler and Turbine MCC. It is provided with a bus coupler to share the load between the two buses.

A low voltage transformer steps down 6.6kV/415V which is given to the 415V bus, which serves as the power source for all the auxiliary equipment connected with the Boiler and Turbine MCC.

Bus A & B supplies power for the Boiler MCC and turbine MCC (A & B) respectively. Both these MCCs are provided with an incoming and an outgoing circuit breaker and a bus coupler to share loads between them.

# Operator Training Simulation Software for Power Generation & Oil and Gas

Isolators are off-load devices that can be used when there is no load on the line, while circuit breakers are on-load devices.

Circuit breakers are available in many types: oil circuit breakers, SF6 circuit breakers & vacuum circuit breakers. Based on the need and speed of operation they can be selected for the switchyard.

From this main bus, power can be transferred to respective substations using individual grid feeders.

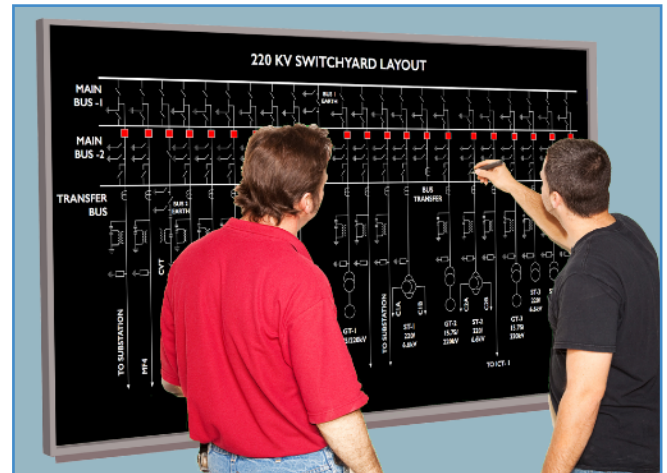
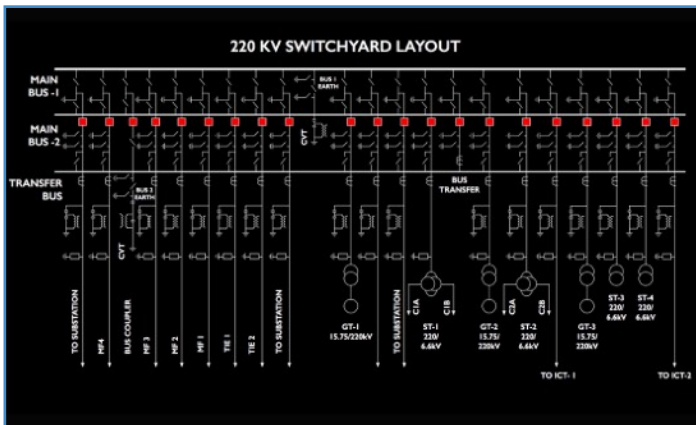

Each individual simulator is fully functional and makes an ideal front of class teaching resource for the Instructor.

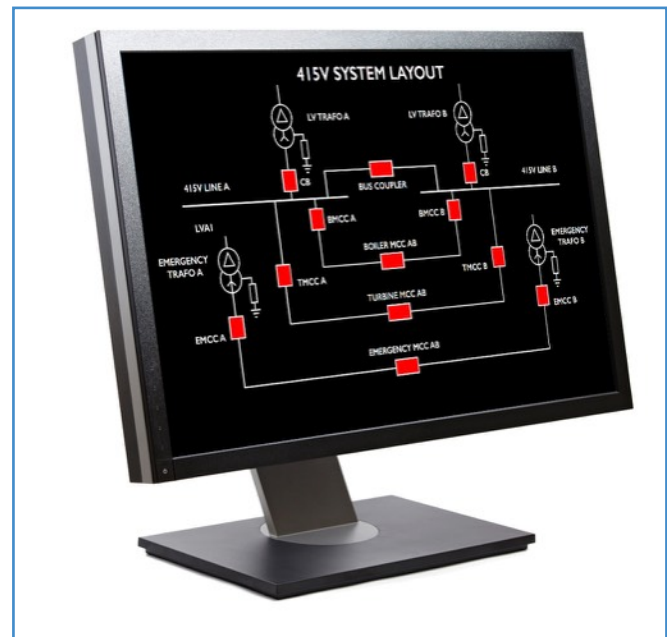

They can also be used for individual instruction on stand alone or networked PCs.

# Operator Training Simulation Software for Power Generation & Oil and Gas

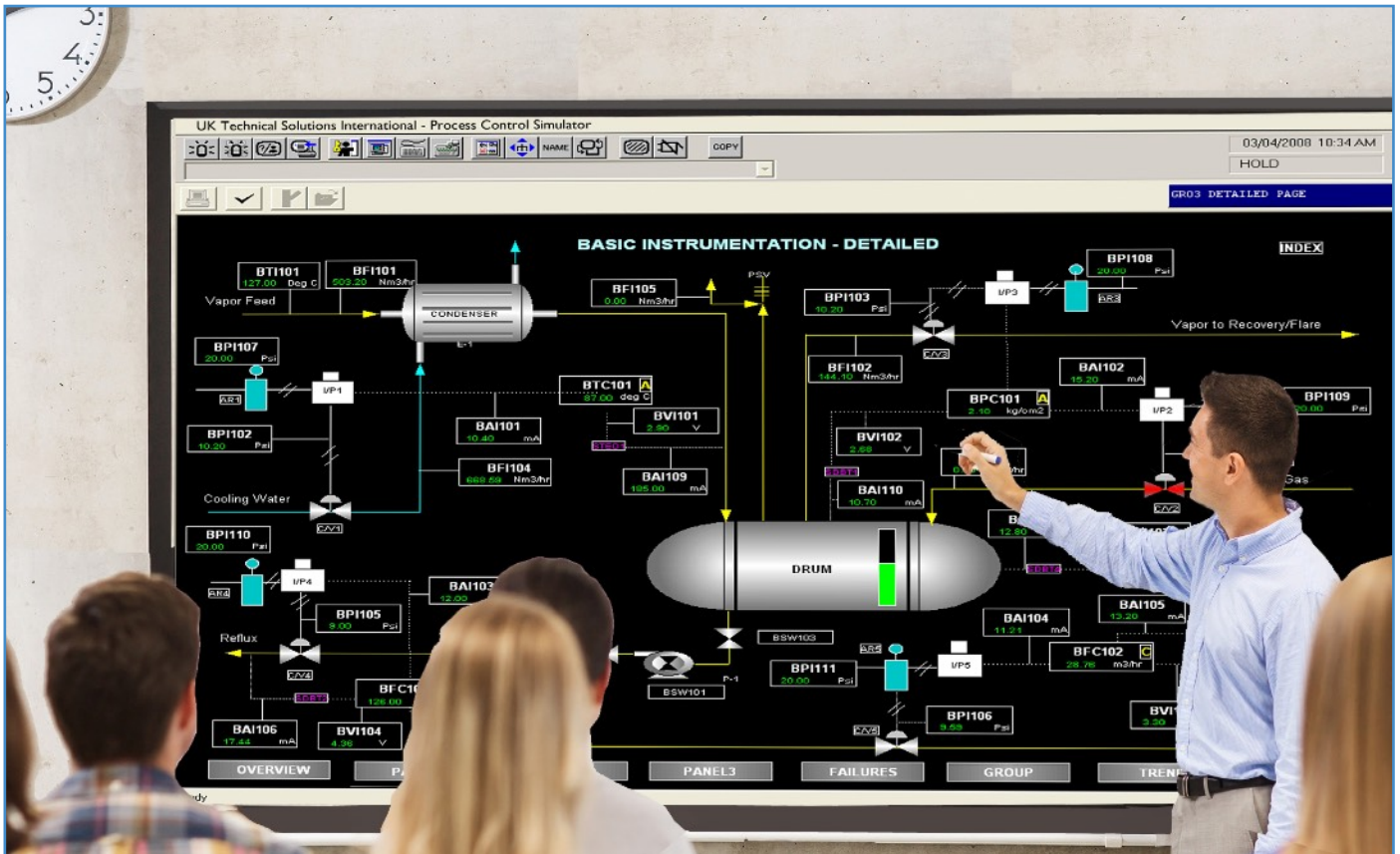

## TSI-PCS/I000 Introduction to Process Control and Instrumentation Simulator

The TSI-PCS/I000 is a simulation software package that has been specifically designed to introduce Oil and Gas Sector trainees to the basic and advanced concepts of Process Control and Instrumentation.

The package consists of the following modules:

- On-Off Level Control
- On-Off Temperature Control
- PI & P Controller
- Pressure Controller
- Level Controller
- Direct and Cascade Control
- Split Range Pressure Control
- Ratio Control
- Feedback and Feed-forward Control
- Three Element Boiler Control
- Control Valve Characteristics
- Characteristics Co-Efficient of Control Valves
- Rangeability of Control Valves
- Interacting and Non-Interacting Level Systems
- Basic Instrumentation Troubleshooting System

Ideal for use as front-of-class presentations for the instructor, this package provides all the main control features such as Trending, Tuning, Alarms and Graphic Panels of a typical DCS system.

Trainees can manipulate Controllers (Take Controllers from Manual to Auto, Auto to Cascade, Change Set Values, change Outputs) and Digital Tags (Start/Stop, Open/Close) and monitor / study their effects on the process.

They can also tune the PID values of a controller.

Using this software, the trainee can learn:

- Basic concepts of measurement and Instrumentation
- DCS operations
- Basic controls – Flow, pressure, level, temperature
- Advanced control – Split range, cascade, ratio, three-element boiler, feed-forward / feedback controls
- Tuning of P.I.D values
- Instrumentation troubleshooting

# Operator Training Simulation Software for Power Generation & Oil and Gas



## Oil and Gas Sector Operator Training Simulators

TSI offer a comprehensive range of affordable, effective operator training solutions that can only be provided through high fidelity, dynamic, real-time simulation. Using simulations for operator training offers a number of benefits that include:

### **Plant familiarisation:**

Each Simulator offers the best platform for learning process plant configuration, instrumentation, control system, critical parameters and their design values and normal plant operations.

### **Ensure smooth start ups:**

Our simulators allow operators to become familiar with plant operation, while they increase their familiarity with the DCS controls and graphical layouts and displays. Continued training ensures increasingly smooth start-ups in the future.

### **Increase safety, reduce incidents and downtime:**

Training personnel in a non-destructive environment enables you to validate emergency procedures controls

Testing modifications to controls can avoid damage. Instructors can trigger malfunctions (such as a trip) to test an operator's reactions and improve response reactions.

### **Maximise performance:**

Our OTS simulators are based on rigorous first-principles models and actual DCS controls, allowing you to troubleshoot real process and control problems.

They unlock the fundamental understanding required to modify, test, and improve processes and maximise plant performance.

### **Benefits to Academic Institutions:**

These Dynamic Simulators help to teach the students the fundamentals as well as complex process operations. They provide an opportunity for the chemical / instrumentation engineering students to know what is happening in the industry.

Simulator-trained students will have an edge over their counterparts in a competitive employment scenario with respect to their knowledge in Instrumentation and Control and Process operations.

# Operator Training Simulation Software for Power Generation & Oil and Gas

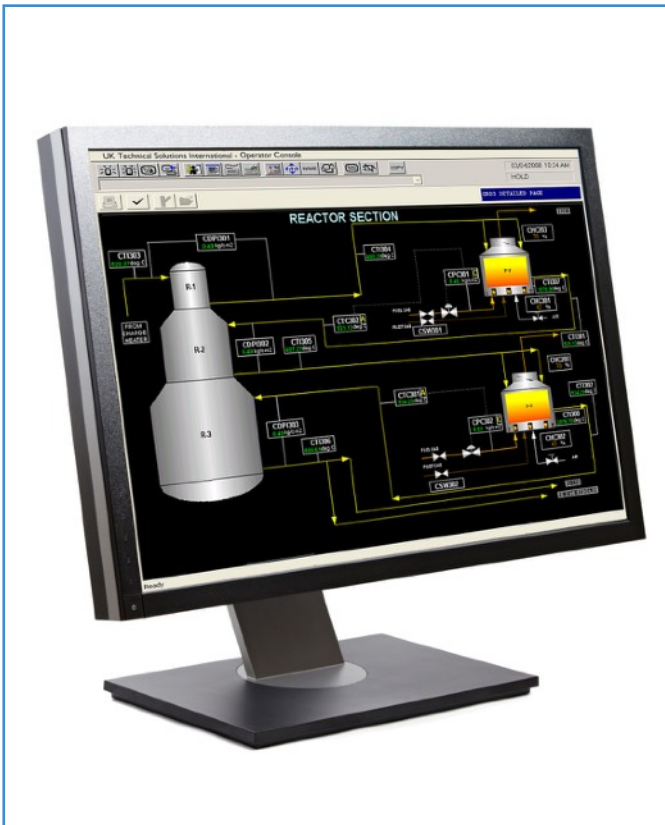

## TSI-ORSD/1000 Refinery Operations (Downstream) OTS Simulator

The TSI-ORSD/1000 is a simulation software package that provides a set of rigorous and detailed simulation models of Refinery process plants.

The package comprises the following modules:

- Atmospheric Distillation Unit
- Vacuum Distillation Unit
- Fluid Catalytic Cracking Unit
- Hydrogen Generation Unit
- Hydrodesphurization Unit
- Catalytic Reforming Unit
- Continuous Catalytic Regeneration Unit
- Hydro-cracking Unit
- Sulphur Recovery Unit
- Amine Treating Unit
- Delayed Coker Unit
- Diesel Hydro-treater Unit
- Naptha Hydrotreating Unit
- Kerosene Hydrotreating Unit

## Training Benefits

This dynamic simulator helps beginners, experienced operators and engineers to achieve the following objectives:

- To teach trainees and to recognise and understand the operating fundamentals of the Crude Oil Distillation process using dynamic simulation.
- To describe the operation of the Crude Oil Distillation process
- To recognise the main equipment found in the Refinery
- To use the DCS to startup and shutdown the various refinery processes using the documented procedures.
- To respond safely and efficiently to disturbances and malfunctions in the process

# Operator Training Simulation Software for Power Generation & Oil and Gas

## TSI-ORSU/1000 Gas Oil Processing Plant OTS Simulator

The TSI-ORSU/1000 is a simulation software package that provides a set of rigorous and detailed simulation models of Gas Oil Separation and processing facilities.

The package consists of the following modules:

- Gas Oil Separation Plant (GOSP)
- Degassing Plant
- Gas Dehydration unit
- Gas Compression Plant
- LPG Unit
- NGL Recovery Unit
- LNG Plant
- 

### Training Benefits

This dynamic simulator helps beginners, experienced operators and engineers to achieve the following objectives:

- To teach trainees to recognise and understand the operating fundamentals of the different Gas Oil Processing operations using dynamic simulation.
- To describe the operation of the Gas Oil Processing operations
- To recognise the main equipment found in a Gas Processing Plant
- To use the DCS to startup and shutdown the various refinery processes using the documented procedures.
- To respond safely and efficiently to disturbances and malfunctions in the process

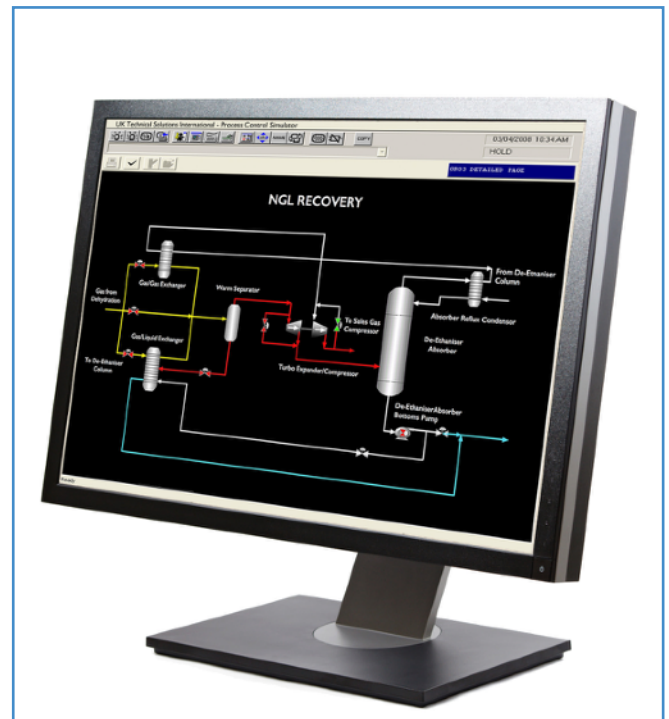



# Technical Solutions International



*Design & specifications of items included in this catalogue are subject to change without notice.*

*Publication Number: 1417/A*

## **UK**

Tel: +44 1252 718 710  
Email: [info@tsi-london.com](mailto:info@tsi-london.com)

[www.tsi-london.com](http://www.tsi-london.com)

## **Dubai**

Tel: +971 4 371 2728  
Email: [info@tsi-dubai.com](mailto:info@tsi-dubai.com)

[www.tsi-dubai.com](http://www.tsi-dubai.com)

## **Sweden**

Tel: +46 36 120 123  
Email: [info@tsi-stockholm.com](mailto:info@tsi-stockholm.com)

[www.tsi-stockholm.com](http://www.tsi-stockholm.com)

















